

MX 9000-100

MX 9000-100

Min conductor	5 mm	0.197"
Max conductor	90 mm	3.540"
Max over insulation	96 mm	3.780"
Max tube die diameter	100 mm	3.940"

Use

Domain of use	Jacketing with any type of cable assembly up to 90 mm
Compound	PVC / PE / PA / LSZH ...

Characteristics

MX 9000-100

MX	Manual centering and fixed centering
SL	Single layer
SS	Skin - Stripe(s)
Distribution mono-flow	Conical distribution cartridge Easy to clean - no holes or slots - no dead spots Constant and smooth compound flow No stress and no shear in the melted compound Distributor support for easy and quick dismantling
Gum space	A bearing allows the axial adjustment of the wire-guide from the back of the head, even under pressure

Design

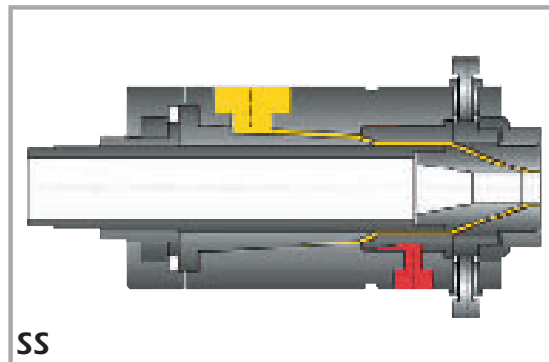
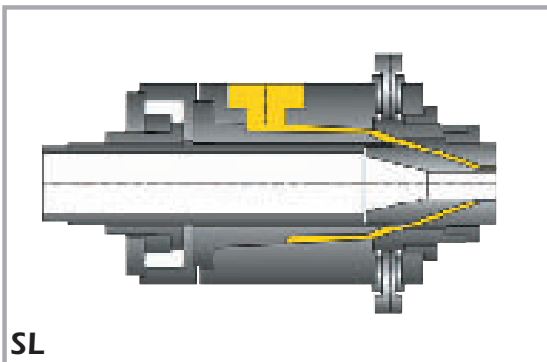

Options

Connections	Connecting flanges for any type of extruders
By-pass	Manual - Hydraulic
Distributor	Special distribution cartridges for "LSZH" - "PA"
Tooling	Hardened steel Semi-compression Tube Special tooling Design recommendation on request
Accessories	Vacuum adapter Assembly and disassembly cleaning kit Trolley with adjustable height
Spare parts	Permanent stock, 24 hours delivery
Services	Microdia answers your request by fax in 24 hours Technical assistance - Engineering - Commissioning